

# QB-FW100-D-20

# Insulated plastic pipe penetrating a flexible or rigid wall (100mm or thicker)

This standard detail is intended for general information only and all details should be checked against all relevant supporting test evidence, certification and installation guidelines. In line with the company's policy of continual development, details are subject to change and/ or withdrawal therefore you must ensure this is the latest published detail and instructions.

**Additional Instructions**

Flexible walls (Insulated or Uninsulated) to have a minimum 50mm wide metal or timber stud and minimum 2no. layer of 12.5mm Gypsum boards in accordance with EN 520 or Calcium Silicate boards which are CE Marked based on an ETA on both sides of the stud. For timber stud walls there shall be a minimum distance of 100mm from the penetration seal to any timber stud and the void between the stud and seal shall be filled with a minimum 100mm depth of Class A1 or A2 insulation.

Apertures / Letterboxes should be constructed in accordance with the fire rated wall system manufacturer's recommendations.

Follow the installation steps referenced in the [QuelStop Fire Batt installation guidance](#) document.

Multiple Service Penetrations: The total amount of cross section area of the services (including insulation) should not exceed 60% of the service penetration area.

Test results obtained with flexible supporting walls may be applied to concrete or masonry elements of an overall thickness equal to or greater than that of the element used in the test.

Detail	Page No.
25mm Depth	1
Full Depth	2

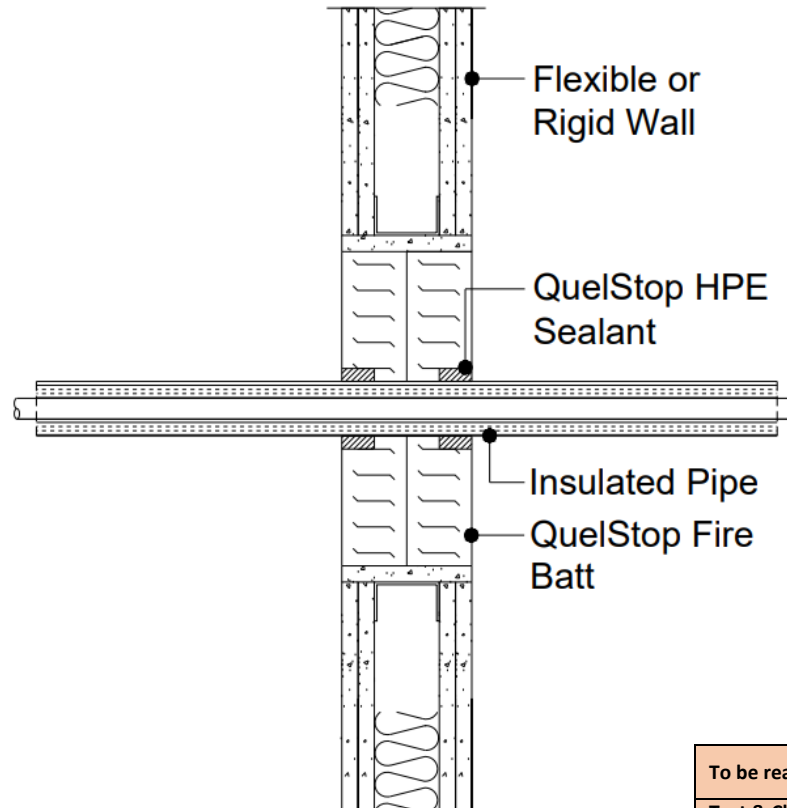

Quelfire Products Required	
Product Code	Description
QB50D	<a href="#">QuelStop Fire Batt</a>
QHPE310	<a href="#">QuelStop HPE Graphite Sealant</a>
QSS310	<a href="#">QuelStop Intumescent Acrylic Sealant</a>
QSC5KG	<a href="#">QuelStop Ablative Coating 5kg tub</a>

**Single Skin Plasterboard Walls**

This standard detail can also be used in conjunction with single skin plasterboard wall systems that are 100mm or thicker and where apertures are framed and lined.

This does however affect the overall scope/fire rating. Please refer to detail [QB-FW100-D-00B](#) for full details and information.

**Unframed and unlined apertures**

Apertures can be lined with QuelStop Fire Batt refer to [QB-FW100-D-00C](#) for further information.

For 100mm thick walls only, this detail can be used in conjunction with [QB-FW100-D-00D](#) for a 700mm wide x 600mm high unframed and unlined aperture.

Multiple Service Penetration Spacing	
Distances are from edge of fire stop seal	
Minimum distance from edge of Opening	0mm
Minimum distance between Services within the table shown	0mm
Minimum distance between other Service types	50mm

Service Type	Size of Service	Pipe Wall Thickness	Pipe Insulation	QuelStop HPE Sealant (installed both sides)	Classification
Pre-Insulated MLC Pipe (Uponor)	≤∅25mm	2.5mm	13mm thick closed cell polyethylene foam ≥150kg/m <sup>3</sup> density (C/S)	10mm Annulus 25mm Depth	EI 120 U/C
Pre-Insulated Polybutylene (PB-1) Pipe	≤∅16mm	2.0mm			
Insulated PE-X pipe	≤∅22mm	2.0mm	9 – 25mm thick Armaflex* (C/S)		

\* Or equivalent elastomeric pipe insulation classified BL-s2, d0 or better to EN13501-1.

<b>To be read in conjunction with:</b>	<a href="#">UL Classification Report 4790517197 Issue 3</a> , Pages 66, 67, 68 & 127
<b>Test &amp; Classification standard:</b>	BS EN1366-3 & EN13501-2
<b>Substrate minimum thickness:</b>	100mm
<b>First Service Support:</b>	≤400mm
<b>Maximum Aperture:</b>	2600mm wide x 1200mm high (Framed & Lined)
Maximum aperture size may be increased to 2600 x 2600mm but limits the fire rating to a maximum of EI60.	
<b>Drawing Scale:</b>	Not to Scale
<b>Issue Number:</b>	3
<b>Date of Issue:</b>	September 2023
<b>Detail Reference:</b>	QB-FW100-D-20

**Important Information:**

- The supporting construction must be installed in accordance with the manufacturer's guidelines and must be capable of achieving the required fire rating of the firestop.
- All services should be adequately supported on both sides of the firestop to ensure that no load is transferred onto the firestop seal.

**Scope and Liability:**

- Any Information provided by or on behalf of Quelfire Limited is provided for general information only. It is not intended to amount to advice on which you should rely. You must obtain professional or specialist advice before taking, or refraining from, any recommendation or action.
- The summary is not exhaustive and does not consider all issues relevant to the enquiry. It is limited to the information and time available to us. We have not verified any information made available to us by you or any other source, nor have we carried out a physical inspection of any property. We make no representations, warranties or guarantees, whether expressed or implied, that any information is accurate, complete or up to date.
- We do not accept a duty of care to you or any other person in respect of the enquiry, nor do we accept any liability to you or any other person for any loss arising out of or in connection with the enquiry or any reply provided by us. Different limitations and exclusions of liability arising as a result of the supply of any products or services by us to you, and these will be set out in our terms and conditions of supply, a copy of which is available on request.
- Full terms and conditions of sale are available at <https://www.quelfire.co.uk/terms-conditions-of-sale/>

# QB-FW100-D-20

# Insulated plastic pipe penetrating a flexible or rigid wall (100mm or thicker)

This standard detail is intended for general information only and all details should be checked against all relevant supporting test evidence, certification and installation guidelines. In line with the company's policy of continual development, details are subject to change and/ or withdrawal therefore you must ensure this is the latest published detail and instructions.

**Additional Instructions**

Flexible walls (Insulated or Uninsulated) to have a minimum 50mm wide metal or timber stud and minimum 2no. layer of 12.5mm Gypsum boards in accordance with EN 520 or Calcium Silicate boards which are CE Marked based on an ETA on both sides of the stud. For timber stud walls there shall be a minimum distance of 100mm from the penetration seal to any timber stud and the void between the stud and seal shall be filled with a minimum 100mm depth of Class A1 or A2 insulation.

Apertures / Letterboxes should be constructed in accordance with the fire rated wall system manufacturer's recommendations.

Follow the installation steps referenced in the [QuelStop Fire Batt installation guidance](#) document.

Multiple Service Penetrations: The total amount of cross section area of the services (including insulation) should not exceed 60% of the service penetration area.

Test results obtained with flexible supporting walls may be applied to concrete or masonry elements of an overall thickness equal to or greater than that of the element used in the test.

Detail	Page No.
25mm Depth	1
<b>Full Depth</b>	<b>2</b>

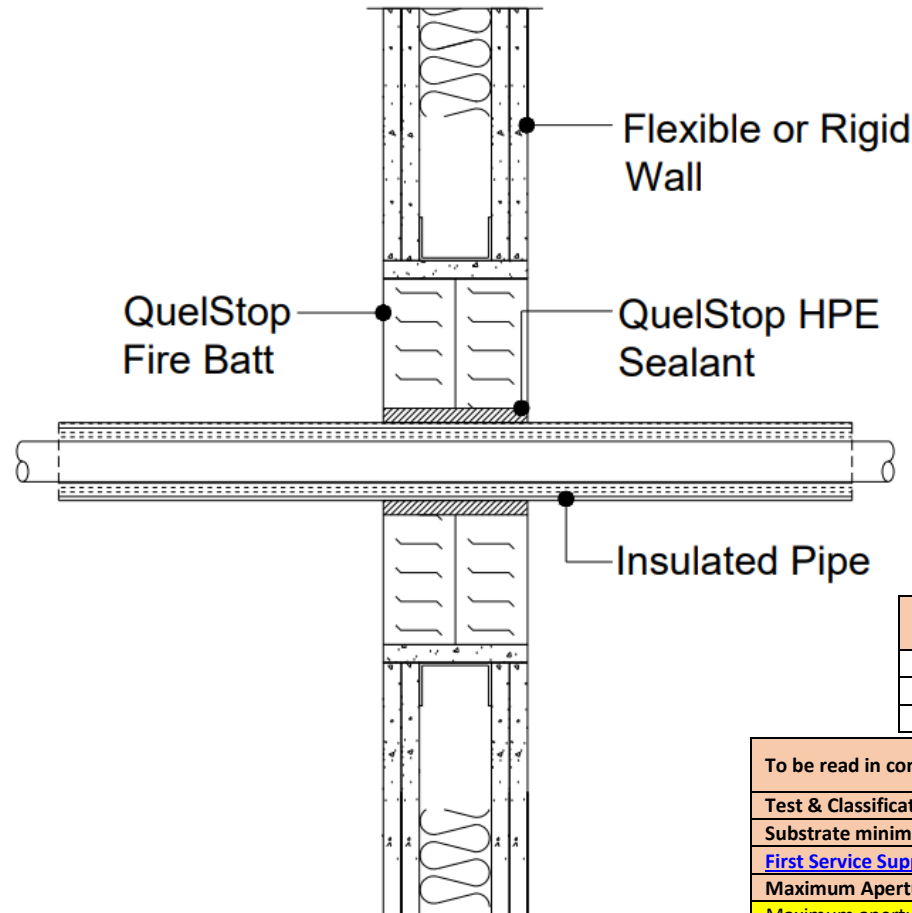

Quelfire Products Required	
Product Code	Description
QB50D	<a href="#">QuelStop Fire Batt</a>
QHPE310	<a href="#">QuelStop HPE Graphite Sealant</a>
QSS310	<a href="#">QuelStop Intumescent Acrylic Sealant</a>
QSC5KG	<a href="#">QuelStop Ablative Coating 5kg tub</a>

**Single Skin Plasterboard Walls**

This standard detail can also be used in conjunction with single skin plasterboard wall systems that are 100mm or thicker and where apertures are framed and lined.

This does however affect the overall scope/fire rating. Please refer to detail [QB-FW100-D-00B](#) for full details and information.

**Unframed and unlined apertures**

Apertures can be lined with QuelStop Fire Batt refer to [QB-FW100-D-00C](#) for further information.

For 100mm thick walls only, this detail can be used in conjunction with [QB-FW100-D-00D](#) for a 700mm wide x 600mm high unframed and unlined aperture.

Multiple Service Penetration Spacing	
Distances are from edge of fire stop seal	
Minimum distance from edge of Opening	0mm
Minimum distance between Services within the table shown	0mm
Minimum distance between other Service types	50mm

<b>To be read in conjunction with:</b>	<a href="#">UL Classification Report 4790517197 Issue 3</a> , Pages 66, 67, 68 & 128
<b>Test &amp; Classification standard:</b>	BS EN1366-3 & EN13501-2
<b>Substrate minimum thickness:</b>	100mm
<b>First Service Support:</b>	≤400mm
<b>Maximum Aperture:</b>	2600mm wide x 1200mm high (Framed & Lined)
Maximum aperture size may be increased to 2600 x 2600mm but limits the fire rating to a maximum of EI60.	
<b>Drawing Scale:</b>	Not to Scale
<b>Issue Number:</b>	3
<b>Date of Issue:</b>	September 2023
<b>Detail Reference:</b>	QB-FW100-D-20

Service Type	Size of Service	Pipe Wall Thickness	Pipe Insulation	QuelStop HPE Sealant (installed both sides)	Classification
Pre-Insulated Polybutylene (PB-1) Pipe	≤Ø28mm	2.0mm	13mm thick closed cell polyethylene foam ≥150kg/m <sup>3</sup> density (C/S)	10mm Annulus Full Depth	E 120 U/C EI 90 U/C

**Important Information:**

- The supporting construction must be installed in accordance with the manufacturer's guidelines and must be capable of achieving the required fire rating of the firestop.
- All services should be adequately supported on both sides of the firestop to ensure that no load is transferred onto the firestop seal.

**Scope and Liability:**

- Any Information provided by or on behalf of Quelfire Limited is provided for general information only. It is not intended to amount to advice on which you should rely. You must obtain professional or specialist advice before taking, or refraining from, any recommendation or action.
- The summary is not exhaustive and does not consider all issues relevant to the enquiry. It is limited to the information and time available to us. We have not verified any information made available to us by you or any other source, nor have we carried out a physical inspection of any property. We make no representations, warranties or guarantees, whether expressed or implied, that any information is accurate, complete or up to date.
- We do not accept a duty of care to you or any other person in respect of the enquiry, nor do we accept any liability to you or any other person for any loss arising out of or in connection with the enquiry or any reply provided by us. Different limitations and exclusions of liability arising as a result of the supply of any products or services by us to you, and these will be set out in our terms and conditions of supply, a copy of which is available on request.
- Full terms and conditions of sale are available at <https://www.quelfire.co.uk/terms-conditions-of-sale/>